

THIS DRAWING IS UNPUBLISHED. RELEASED FOR PUBLICATION  
 © COPYRIGHT - By - ALL RIGHTS RESERVED.

LOC	DIST	REVISIONS			
P	LTR	DESCRIPTION	DATE	DWN	APVD
AF	50				
	P	REVISED PER ECR-13-011489	09DEC2013	KH	PD

- 1 SUFFIX LETTER MUST BE USED ONLY WHEN ORDERING APPLICATOR TOOLING FOR STEPPED UP VERSION.
- 2 CONTINUOUS STRIP ON REELS.
- 3 WIRE SIZE IS 0.8-2.0MM<sup>2</sup> [18-14] AWG.
- 4 INSULATION RANGE IS 3.05-4.32 [.120-.170] DIA.
- 5 REELED WITH PAPER INTERLEAVING.
- 6 PRELIMINARY - NOT FOR PRODUCTION.

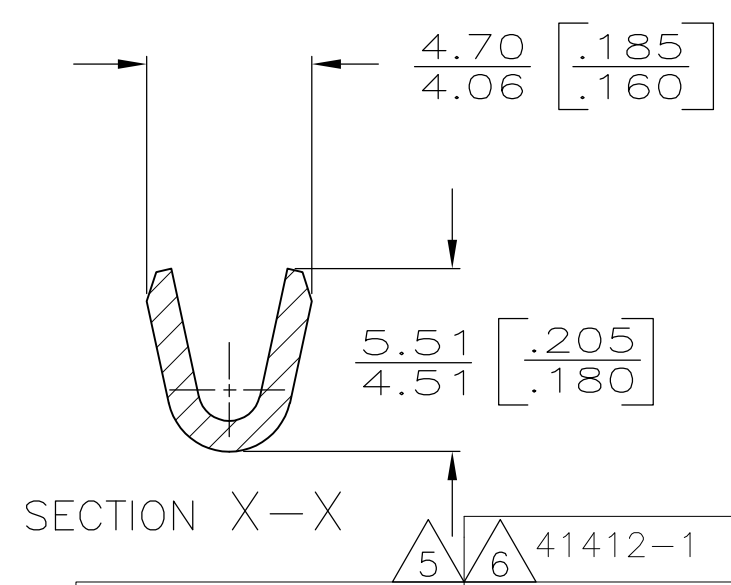
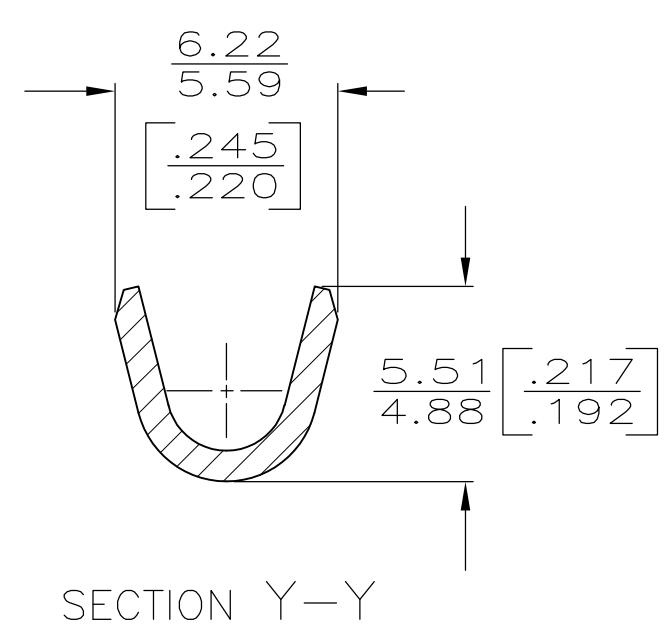
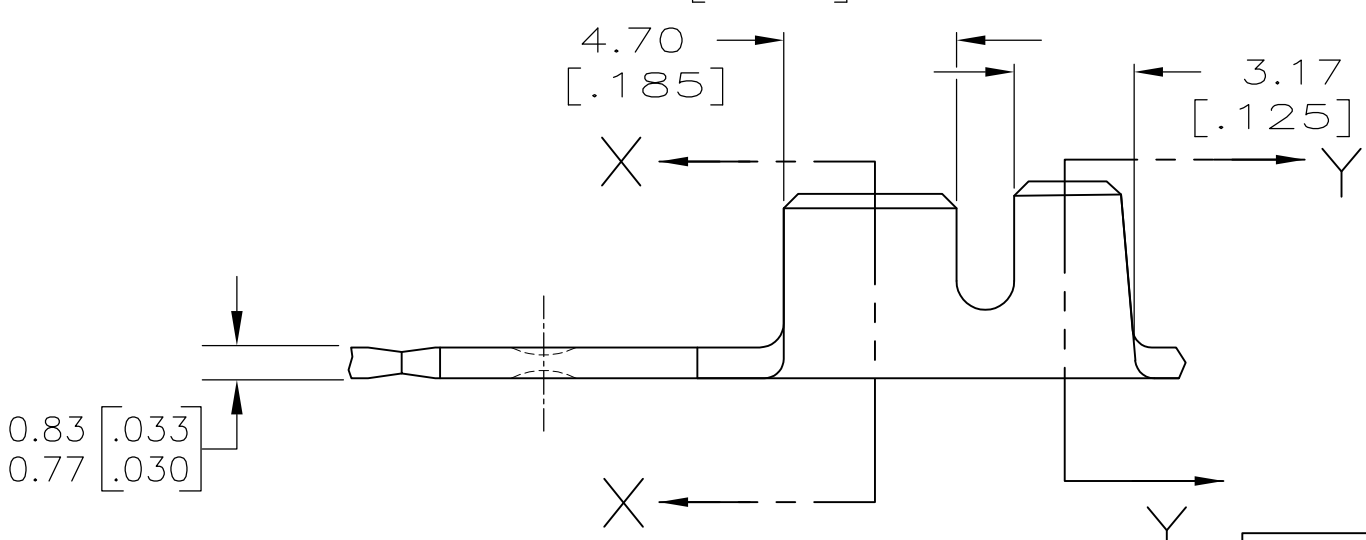
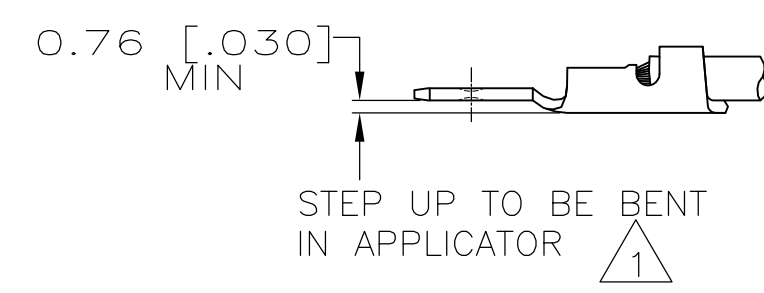
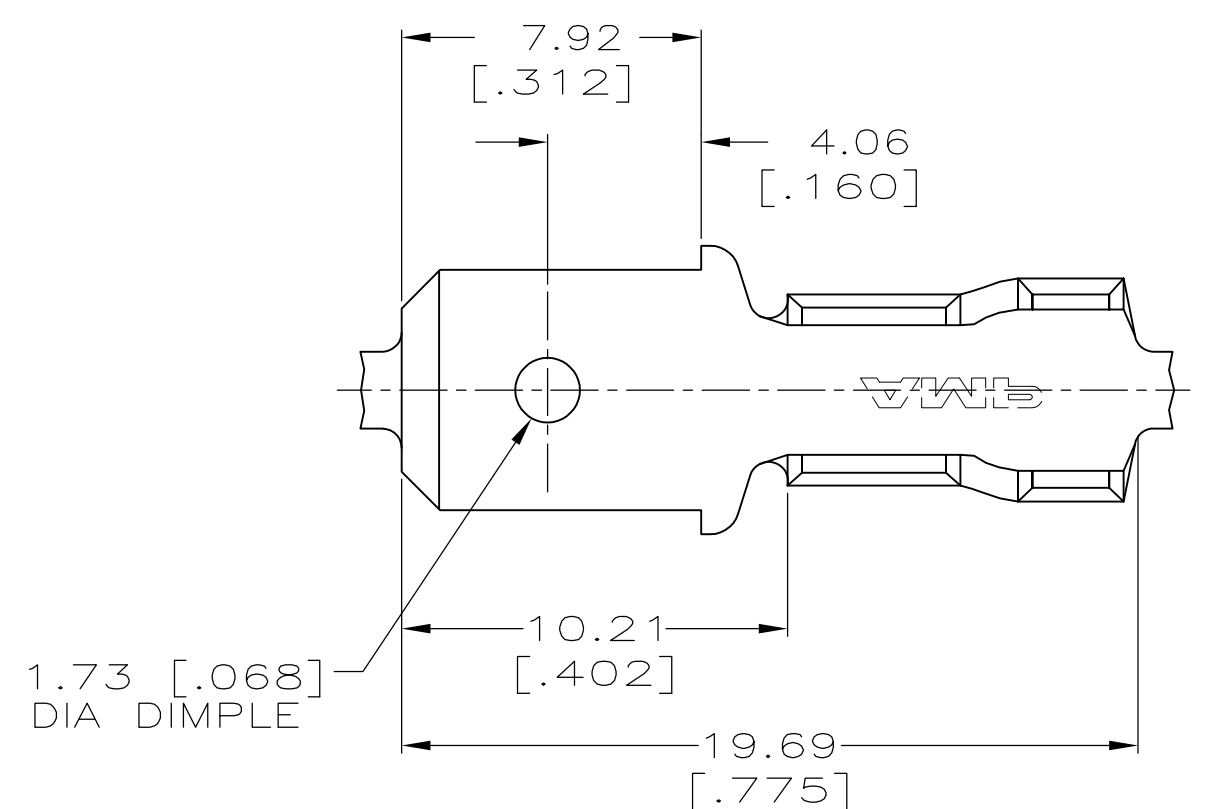

41412 B	41412
TERMINAL NUMBER STEPPED UP	PART NO.

THIS DRAWING IS A CONTROLLED DOCUMENT.		DWN	JR RUTH	2/5/92	TE Connectivity STEPPED UP	NAME			RESTRICTED TO						
DIMENSIONS: mm [INCHES]		CHK	MS FEHER	2/5/92		TAB, FASTON, 6.35 [.250] SERIES									
TOLERANCES UNLESS OTHERWISE SPECIFIED:		APVD	D REINER	2/5/92		PRODUCT SPEC									
0 PLC ± - 1 PLC ± - 2 PLC ± - 3 PLC ± 0.38 [.015] 4 PLC ± - ANGLES ± -		APPLICATION SPEC		SIZE											
MATERIAL	BRASS	FINISH	TIN	WEIGHT	-	CAGE CODE	A300779	DRAWING NO	C-41412	SCALE	5:1	SHEET	1 OF 1	REV	P
CUSTOMER DRAWING										SCALE 5:1		SHEET 1 OF 1		REV P	